

AB-BAT12-7Ah 12V7Ah

● Specifications

Nominal Voltage		12V
Rated capacity (20 hour rate)		7.2Ah
Dimensions	Length	151±1.5mm(5.94inch)
	Width	65±1mm(2.56inch)
	Height	94±1mm(3.70inch)
	Total Height	100±1mm(3.94inch)
Approx. Weight		2.2kg(4.85lbs)±4%



● Outer dimensions (mm)

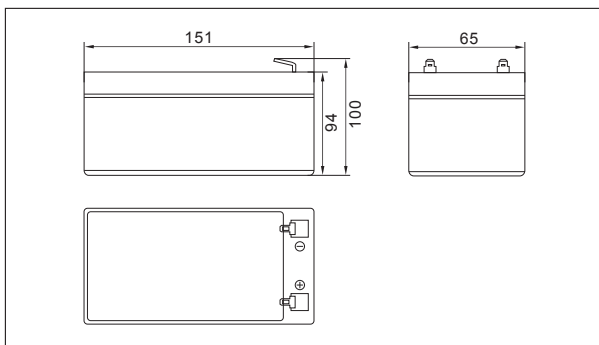

● Terminal Type (mm)

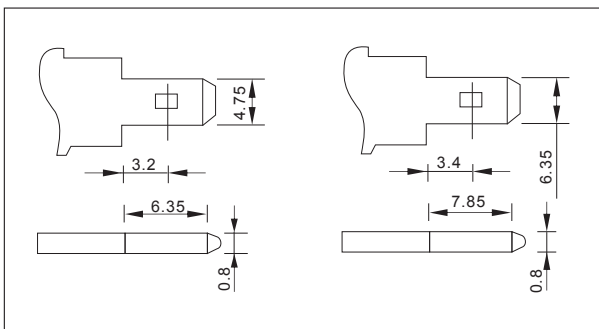

● Construction

Component	Positive plate	Negative plate	Container	Cover	Separator	Electrolyte	Safety valve	Terminal
Raw material	Lead dioxide	Lead	ABS	ABS	AGM	Sulfuric acid	Rubber	Copper

● Constant Current Discharge Characteristics Unit:A(25°C,77°F)

F.V/Time	5min	10min	15min	30min	60min	2h	3h	4h	5h	10h	20h
9.60V	28.7	18.2	14.2	7.99	4.91	2.69	1.86	1.54	1.31	0.71	0.38
9.90V	27.8	17.6	13.8	7.83	4.84	2.67	1.85	1.53	1.30	0.71	0.38
10.2V	26.6	16.9	13.3	7.59	4.72	2.65	1.84	1.52	1.29	0.70	0.38
10.5V	25.5	16.2	12.9	7.40	4.62	2.61	1.82	1.51	1.28	0.70	0.38
10.8V	24.1	15.2	12.2	7.13	4.48	2.54	1.77	1.46	1.24	0.69	0.37

● Constant Power Discharge Characteristics Unit:W(25°C,77°F)

F.V/Time	5min	10min	15min	30min	60min	2h	3h	4h	5h	10h	20h
9.60V	320	205	162	91.5	56.9	31.4	22.1	18.3	15.6	8.52	4.57
9.90V	310	199	158	89.7	56.0	31.3	22.0	18.2	15.5	8.49	4.55
10.2V	297	190	152	87.0	54.6	31.0	21.8	18.1	15.4	8.45	4.53
10.5V	285	182	147	84.9	53.5	30.5	21.7	18.0	15.3	8.40	4.50
10.8V	269	172	139	81.7	51.9	29.7	21.0	17.4	14.9	8.23	4.41

Note: The above characteristics data can be obtained within three charge or discharge cycles.

● Characteristics

Capacity (25°C)	20HR(10.5V)	7.2Ah
	10HR(10.5V)	7Ah
	1HR(9.60V)	4.6Ah
Terminal type		T1/T2
Internal resistance (Fully charged,25°C)		Approx.21m Ω
Capacity affected by temperature (20HR)	40°C	102%
	25°C	100%
	0°C	85%
	-15°C	65%
Self-discharge (25°C)	3month	Remaining Capacity:91%
	6month	Remaining Capacity:82%
	12month	Remaining Capacity:65%
Nominal operating temperature		25°C ±3°C(77°F ±5°F)
Operating temperature range	Discharge	-15°C~50°C(5°F~122°F)
	Charge	-10°C~50°C(14°F~122°F)
	Storage	-20°C~50°C(-4°F~122°F)
Float charging voltage(25°C)		13.60 to 13.80V Temperature compensation: -18mV/°C
Cyclic charging voltage(25°C)		14.50 to 15.00V Temperature compensation: -30mV/°C
Maximum charging current		2.25A
Maximum discharge current		112.5A(5 sec.)
Designed floating life(20°C)		5 years

AB-BAT12-7.5Ah 12V7.5Ah

Discharge characteristics(25°C)

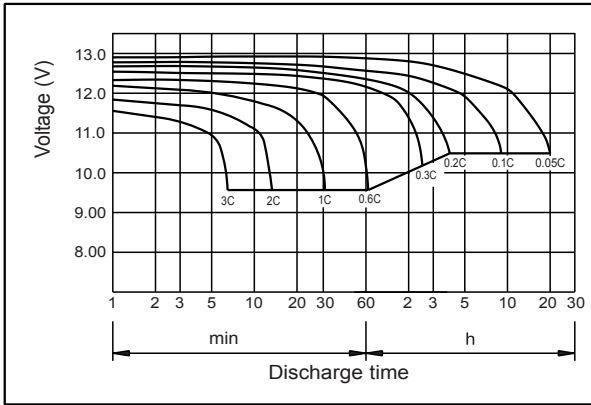

Charging characteristics (25°C)

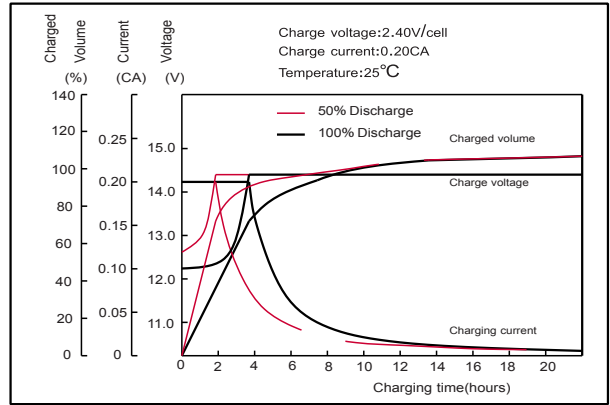

Effect of temperature on capacity

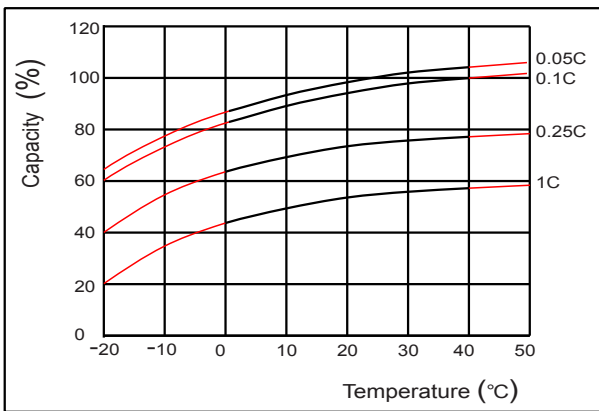

Self-discharge characteristics

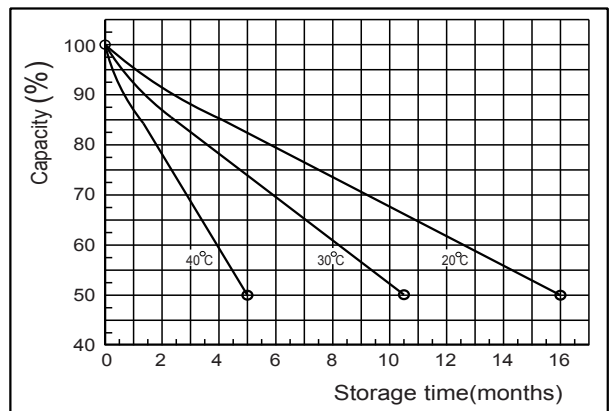

Floating life on temperature

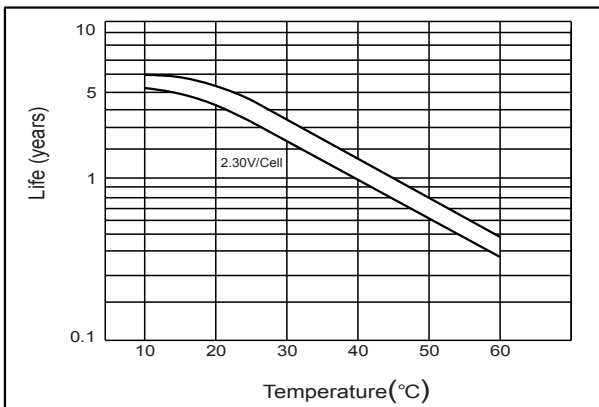

Cycle life on D.O.D(25°C)

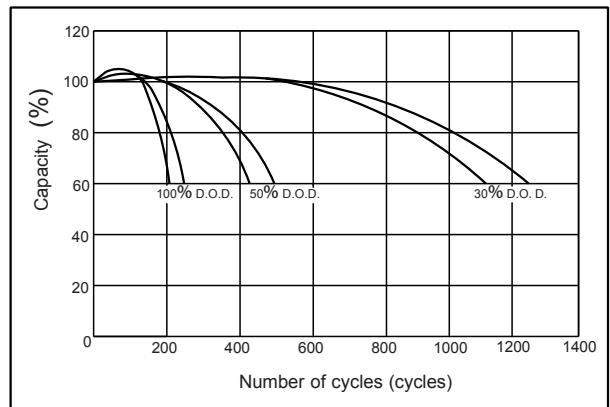

The relationship for OCV and Capacity (25°C)

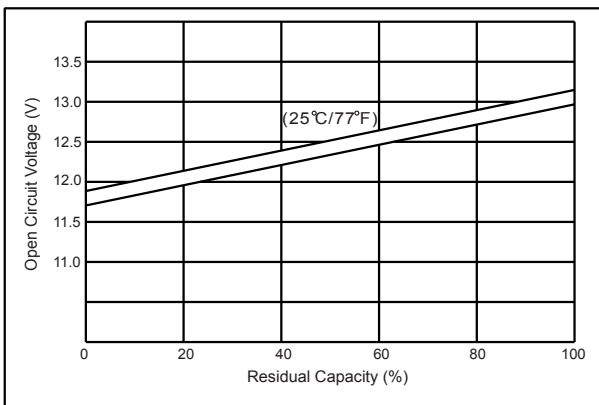

The relationship for Charging voltage and Temperature

